

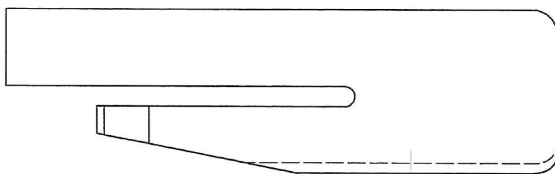

INSPECTION BULLETIN

Side Sill Closure Inspection and Repair

This inspection Bulletin provides details for the inspection and modification of side sill closure plates on ACF built Center Flow® covered hopper cars. The closure plate may be referred to as the pistol plate, or hair pin closure.



Built Years: 1978–1981

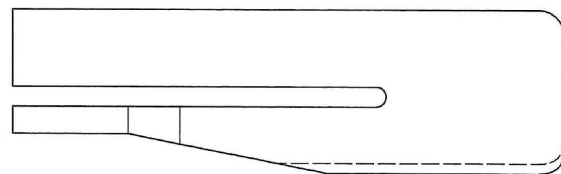

Built Years: 1981–2005

The side sill closure plate was utilized from 1978 – 2005. The areas shown below should be inspected for discontinuities in the form of cracks emanating from the welds at the inboard end of the closure plate attachment to the side sheet and at the bolster bottom cover attachment to the side sill. In all cases, replacement with a new closure plate is recommended at all four corners.

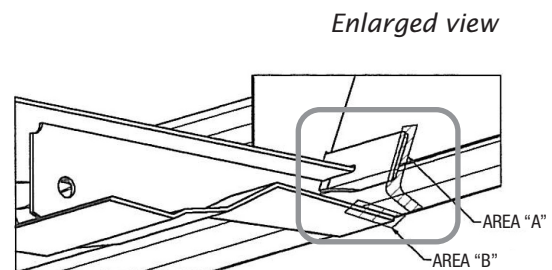
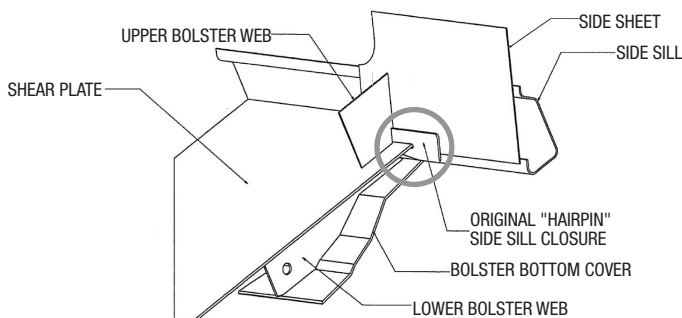

Inspection & Repair of Inboard Weld Termination

Inspection:

- Remove all dirt and debris from Areas "A" and "B" by wire brushing.
- Dye-penetrant inspect these areas.
- If no cracking is found proceed with replacement of the side sill closure plate (recommended), or return the car to service. If the car is returned to service without replacement of the closure plate a plan should be implemented to inspect this area on a routine basis.

Cracks emanating from the welds can propagate up into the side sheet and down to the inside radius of the side sill and outward along the bottom of the side sill.

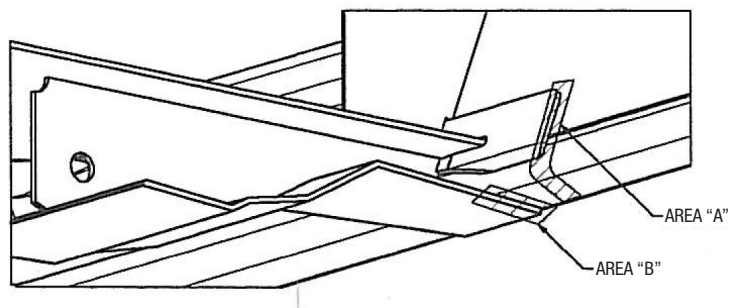

Critical Note: If any of the following special conditions are observed it will be necessary to replace a section of the side sill. See "Side Sill Section Replacement."

- A crack that splits and branches in multiple directions
- Two or more cracks within 3" of one another
- A crack that is open 1/32" or greater
- A crack that propagates into the outside radius of the side sill, see below.

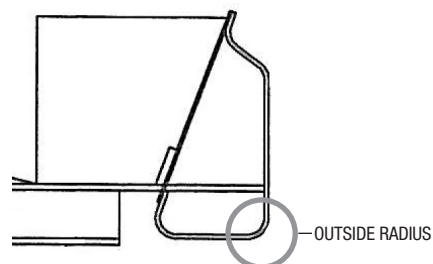

Side Sill Closure Plate – Removal

- Remove the side sill closure plate by air arc or burning.

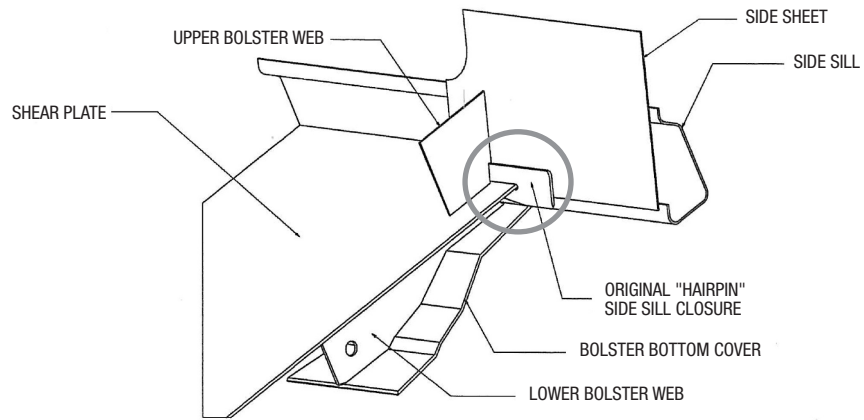

- Remove a section of the bolster bottom cover and bolster web.

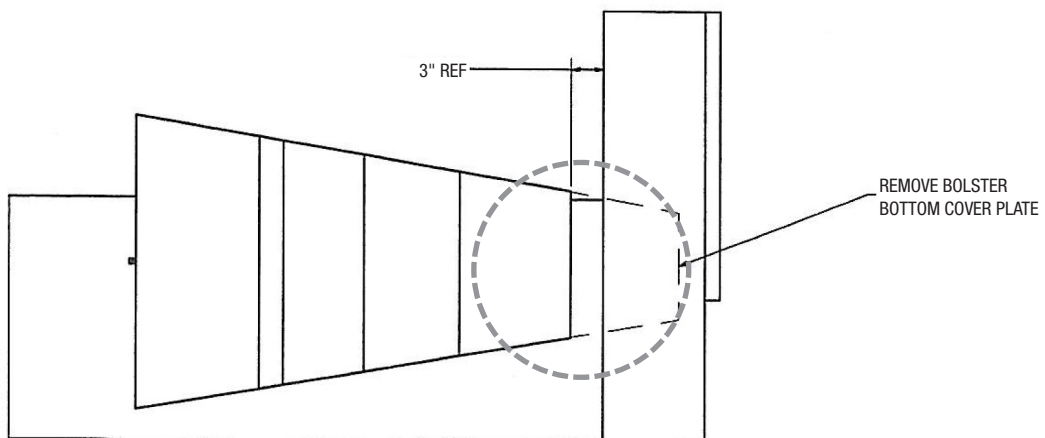
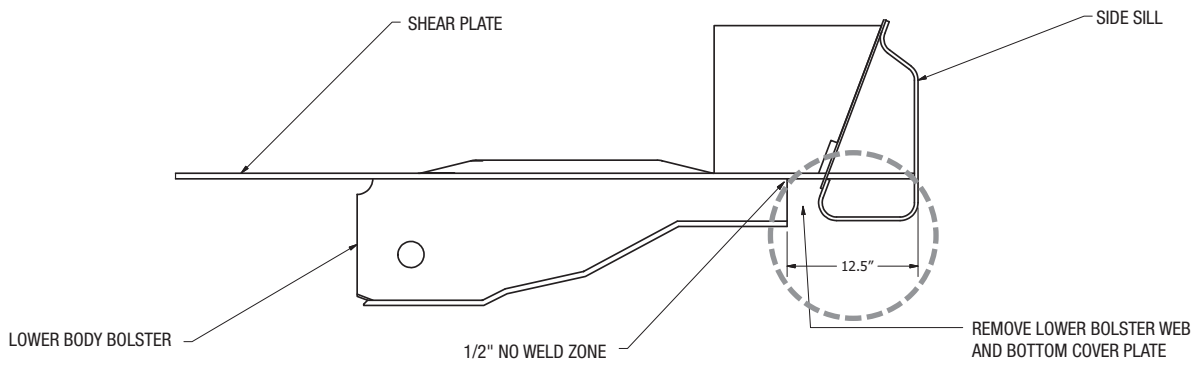

Side Sheet Inspection & Repair

- With the closure plate removed, dye-penetrant inspect the side sheet, and the inboard and underside of the side sill for cracks.
- Any surface that is gouged due to removal of the closure plate, 1/16" deep or greater, will require repair. Use E7018 electrode or equivalent wire and grind smooth.
- All grinding is to be in the horizontal direction, longitudinal to the car body.
- Repair side sheet cracks, see highlighted section below, by gouging out the crack and welding.

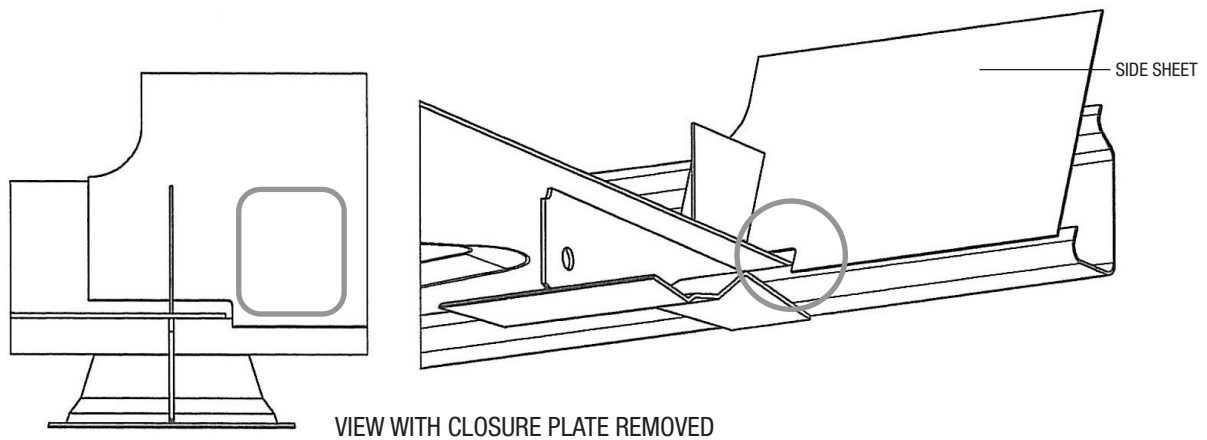

Side Sill Inspection & Repair Procedures

Inspection

- With the closure plate removed, dye-penetrant inspect area "A."

Repair

- Side sill cracks must be repaired from both sides.
- Access to the interior of the side sill is gained by cutting a window, 8" vertical x 12" horizontal, in the outside vertical flat of the sill. Radius the corners to 2" minimum. Save the cutout scrape to seal the access window when the repair is completed.
- The outboard edge of the opening must be 1-1/2" from the inboard edge of the shear plate.
- Beginning inside the sill, remove the crack by air arcing the affected area plus 1/2" beyond the crack length to a depth of 1/4". Prepare the area for welding.
- Weld the area using E7018 electrodes or equivalent wire. Weld first pass stringer and weave the remaining passes.
- Prepare the outside surface with air arc to a depth that will ensure a 100% weld penetration in weld. Prepare the area for welding.
- Weld the area using E7018 electrodes or equivalent wire. Weld first pass stringer and weave the remaining passes.
- Close the access window by preparing the edges of the sill opening and the saved panel.
- Apply 1/8" x 2" wide back-up strips inside window opening.
- Replace the panel section and weld with E7018 electrodes or equivalent wire ensuring 100% penetration.

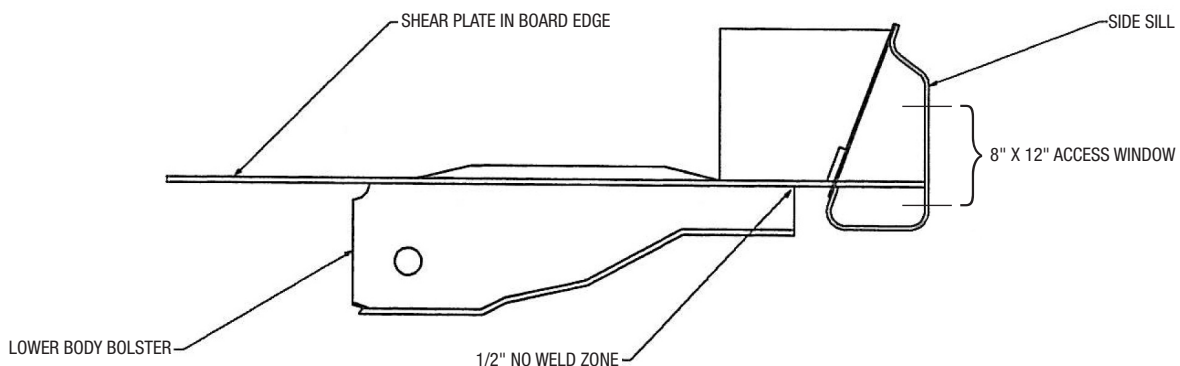

Side Sill Section Replacement

From the Critical Note on page 2, certain conditions necessitate replacing a section of the side sill. This area is defined as the "Critical Repair Area," and extends from the centerline of the adjacent compartment to a minimum of 8" beyond the centerline of the body bolster, or if desired, to the end of the car.

Conditions requiring replacement of the side sill section:

- A crack that splits and branches in multiple directions
- Two or more cracks within 3" of one another
- A crack that is open 1/32" or greater
- A crack that propagates into the outside radius of the side sill.

Procedure

- Remove the Critical Repair Area sill section using air arc and exercising caution to avoid damage to the horizontal shear plate and side sheets.
- A tie plate connecting the bottom of the side sill to the compartment slope sheet is located at the centerline of each compartment. Split the tie plate in the middle and replace the side sill section by fitting a 1/8" x 2" back-up strip and butt welding the two sections together using E7018 electrode or equivalent wire and ensuring 100% penetration.
- Relocate the roping staple 12" outboard of the body bolster web.
- Apply the previously removed section of tie plate and butt weld the two sections together.

Side Sill Closure Plate – Replacement

CRITICAL NOTE: All four corners of the car must be modified when applying the new design side sill closure plate.

- Repair all nicks, gouges, and undercuts, 1/16" deep or greater, in the side sill using E7018 electrode or equivalent wire and grind smooth. All grinding to be horizontal, or longitudinal to the car body.
- Tack weld new side sill closure plate into position, detail E. The opening in the upper bolster web may need to be enlarged to accommodate new closure plate.
- Weld closure plate to the shear plate, side sill and side sheet per section D-D. Note – The no weld zones are critical and must not be violated.
- Caulk the inboard no weld zones.
- Touch up repairs with matching paint.

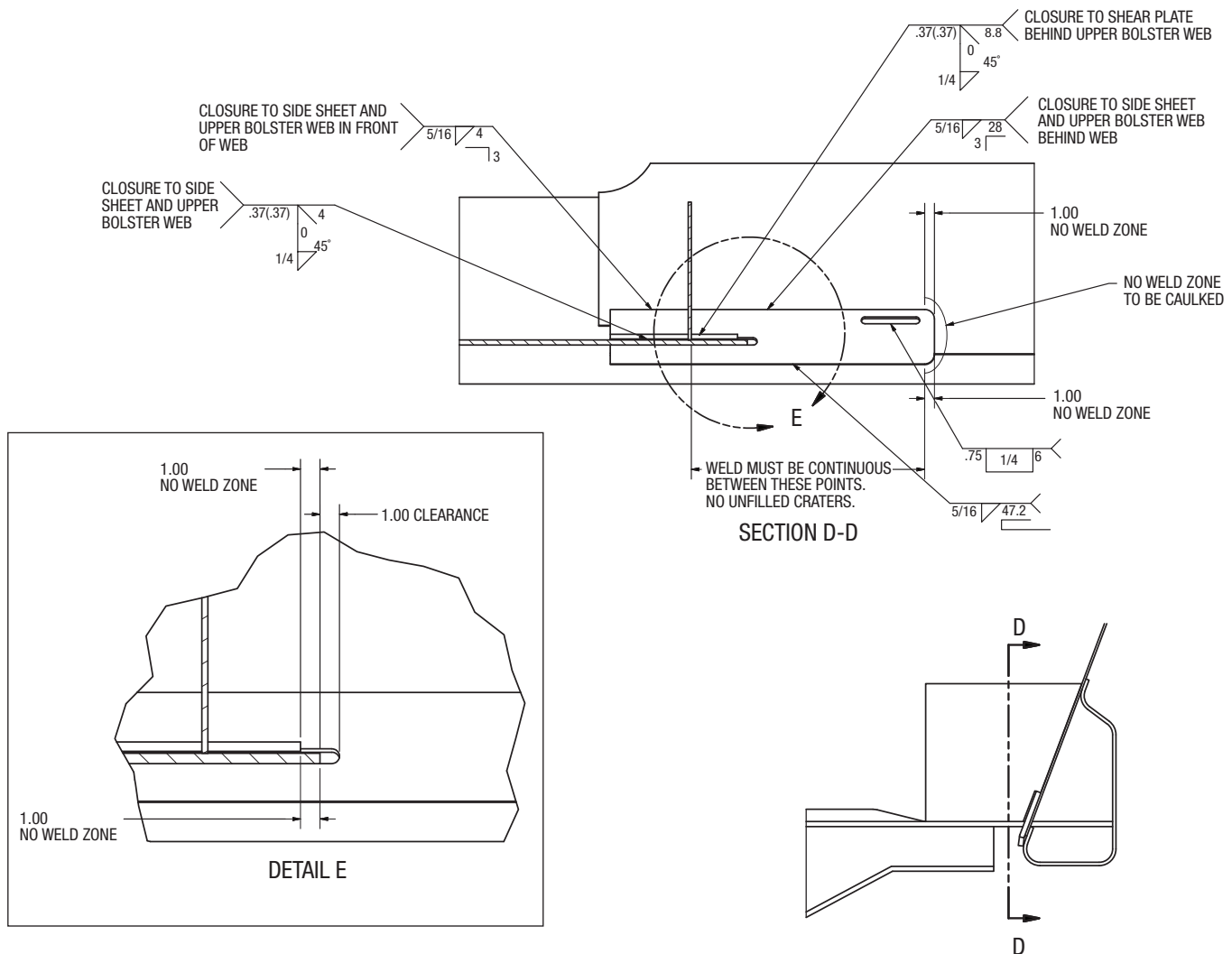

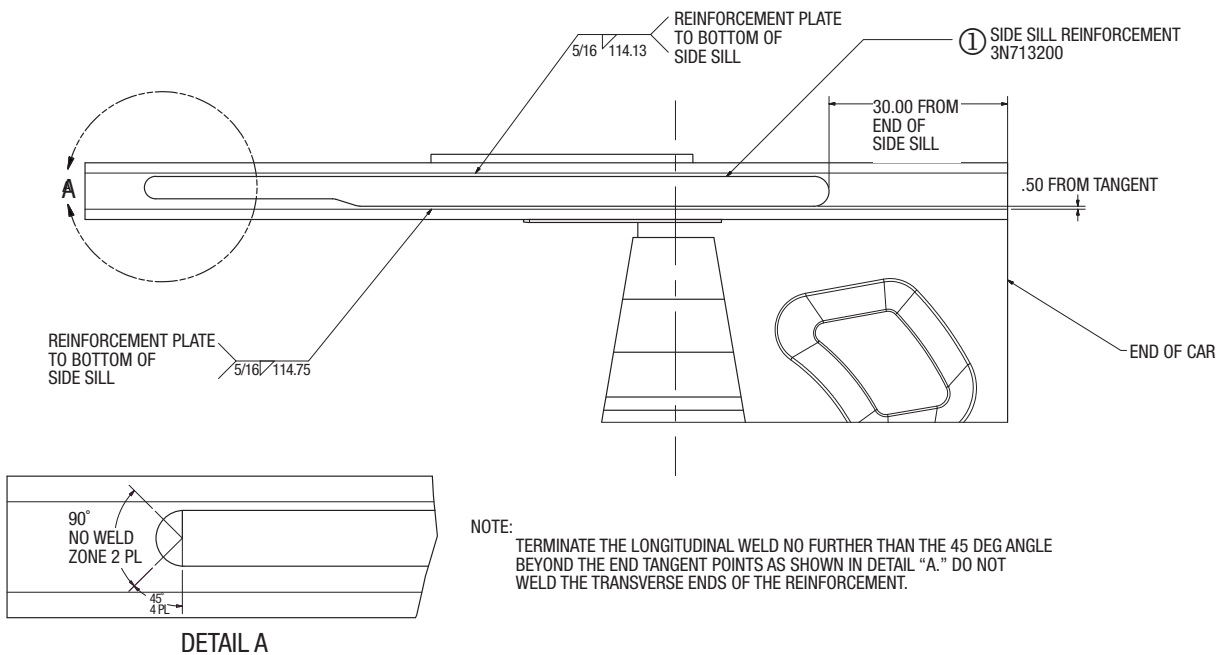
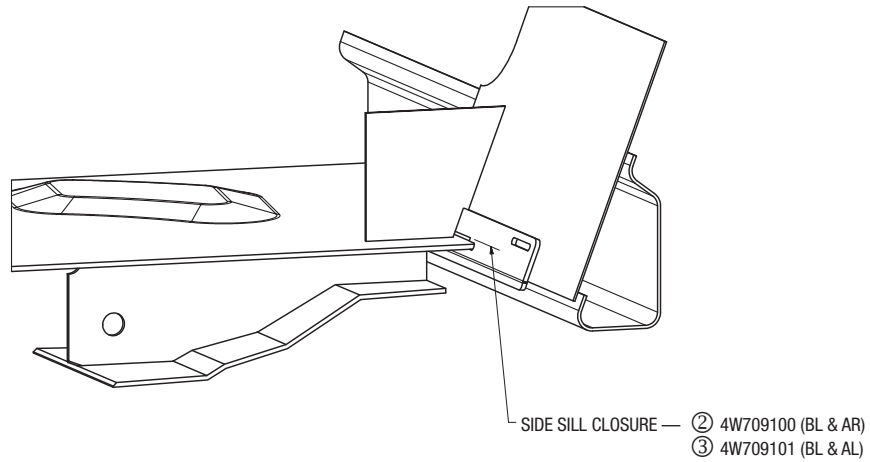

- ① Side Sill Reinforcements – 3N713200, 4 required
- ② Side Sill Closure Plate – 4W709100, 2 required
- ③ Side Sill Closure Plate – 4W709101, 2 required

ARI makes no representations or warranty, express or implied, with respect to the contents herein, and assumes no contractual or other liability with respect to any use which the customer may make of this Information Bulletin.



AMERICAN RAILCAR INDUSTRIES, INC.

100 Clark Street, St. Charles, Missouri 63301

636.940.6020 • FAX: 636.940.6100

www.americanrailcar.com • sales@americanrailcar.com